

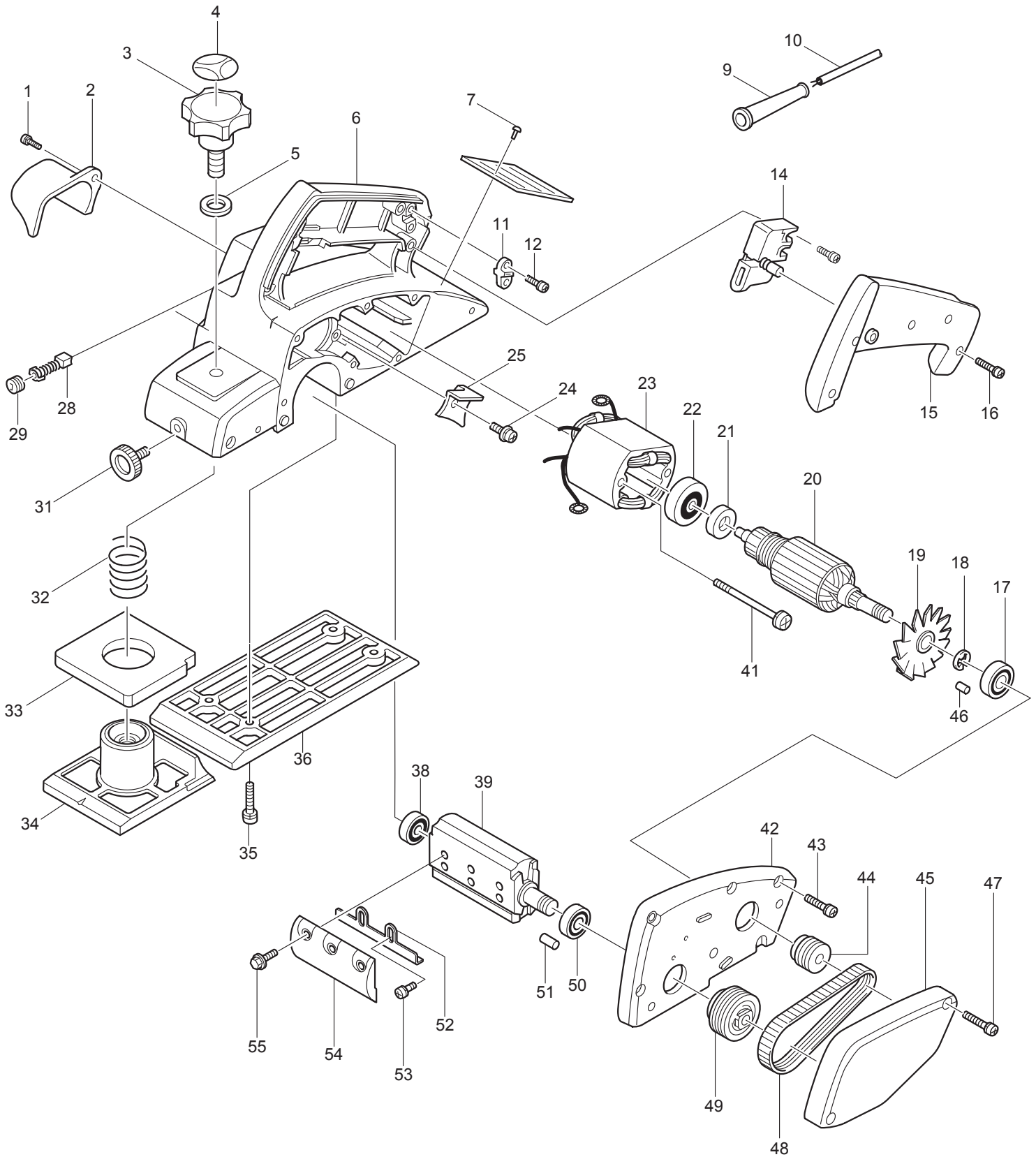

11 - 2010
N1900B / N1900BK
3-1/4" POWER PLANER



Item No.	Type	Sub	Part No.	Description (* See Service Changes on the bottom)	Q'ty	Unit
1			265874-8	* TAPPING SCREW BT 4X20	1	PC.
			265941-9	* TAPPING SCREW BT 4X18	1	PC.
2			411650-0	CHIP COVER	1	PC.
3			271231-0	KNOB 46	1	PC.
4			812137-9	SCALE LABEL (INCH)	1	PC.
5		1	253796-4	* FLAT WASHER 10	1	PC.
		2	941251-5	* FLAT WASHER 10	1	PC.
6			159858-5	* MAIN FRAME COM.	1	PC.
		INC.	643556-6	* BRUSH HOLDER 5-8	2	PC.
9			682502-4	CORD GUARD 8-85	1	PC.
10			664064-4	CORD W/PLUG 2P-18-2.5M, SJ	1	PC.
11			687063-9	CORD CLAMP	1	PC.
12			265941-9	* TAPPING SCREW BT 4X18	2	PC.
14			651232-8	* SWITCH (W/ LOCK ON BUTTON)	1	PC.
15			415676-4	* HANDLE COVER (W/LOCK ON BUTTON HOLE)	1	PC.
16			265875-6	* TAPPING SCREW BT 4X25	4	PC.
17			211061-7	BALL BEARING 6000LLB	1	PC.
18			961015-1	STOP RING E-9	1	PC.
19			241510-0	FAN 52	1	PC.
20			517036-7	ARMATURE ASS'Y 115V	1	PC.
		INC.		Item No. 17-19,21,22		
21			681614-0	INSULATION WASHER	1	PC.
22			211028-5	BALL BEARING 627LB	1	PC.
23			593241-0	FIELD ASS'Y 115V	1	PC.
		INC.	654018-9	RING TERMINAL	2	PC.
		INC.	654555-3	CONNECTOR 34130	2	PC.
24			265871-4	* TAPPING SCREW BT 4X16	1	PC.
25			411153-4	AUXILIARY BAFFLE PLATE	1	PC.
26			911111-5	* P.H.SCREW M5X18 (Old)	1	PC.
27			285012-6	* BEARING COVER (Old)	1	PC.
28		1	191947-0	CARBON BRUSH CB-76 2PC/SET (W/O ORIGIN) - N/L/A	1	SET
		2	194972-0	CARBON BRUSH CB-76 2PC/SET (W/ ORIGIN)	1	SET
		Opt.	181500-0	AUTO CUT-OFF CARBON BRUSH CB60 (W/O ORIGIN)	1	SET
29			643550-8	BRUSH HOLDER CAP 5-8	2	PC.
31			251812-6	SCREW M5X10	1	PC.
32			231004-3	COMPRESSION SPRING 18	1	PC.
33			421007-7	RUBBER PACKING	1	PC.
34			312566-1	FRONT BASE	1	PC.
35			265878-0	* TAPPING SCREW BT 5X16	4	PC.
36			312023-9	BASE	1	PC.
37			263002-9	* RUBBER PIN (Old)	1	PC.
38			211032-4	BALL BEARING 608ZZ	1	PC.
39			161061-6	DRUM	1	PC.
40			263014-2	* RUBBER PIN (Old)	1	PC.
41			265877-2	* TAPPING SCREW BT 4X60	2	PC.
42			156313-8	BRACKET COMPLETE	1	PC.
		INC.		Item No. 46,51		
43			265875-6	* TAPPING SCREW BT 4X25	6	PC.
44		1	222008-6	* V-PULLEY 4-20L - N/L/A	1	PC.
		2	222125-2	* V-PULLEY 4-20L (OLD# 222008-6 - N/L/A)	1	PC.
45		1	411019-8	BELT COVER (BLACK W/ RED LOGO) - N/L/A	1	PC.
		2	450051-7	BELT COVER (BLUE W/ WHITE LOGO)	1	PC.
46			263002-9	RUBBER PIN 4	1	PC.
47			911148-2	PAN HEAD SCREW M4X25	2	PC.
48			225007-7	POLY V-BELT 4-241	1	PC.
49		1	222009-4	* V-PULLEY 4-37	1	PC.
		2	222126-0	* V-PULLEY 4-37	1	PC.
50			211062-5	BALL BEARING 6000ZZ	1	PC.
51			263002-9	RUBBER PIN 4	1	PC.

Item No.	Type	Sub	Part No.	Description (* See Service Changes on the bottom)	Q'ty	Unit
52	1		342430-2	* ADJUST PLATE	2	PC.
	2		345644-2	* ADJUST PLATE	2	PC.
53	1		251246-3	* + PAN HEAD SCREW M4X5	4	PC.
	2		265132-2	* + PAN HEAD SCREW M4X5	4	PC.
54			345007-2	DRUM PLATE (2PCS/SET)	1	SET
55			251609-3	HEX. FLANGE HEAD BOLT M6X17	6	PC.
58			913206-0	SET SCREW M5X8 (Old)	2	PC.
60			343433-9	SET PLATE F/MINI BLADE	2	PC.
	Opt.		193540-6	SET PLATE 2PC/SET	1	SET
200			652008-6	P.H.SCREW M3.5X7 (F/WIRING)	4	PC.
201			654037-5	INSULATED EYE TERMINAL FV1.25-M3 (F/WIRING)	4	PC.

ACCESSORIES

- See catalogue or visit www.makita.ca for other optional accessories -

A01			123004-6	SHARPENING HOLDER ASS'Y	1	PC.
	INC.		934301-3	WING NUT M6	2	PC.
	INC.		251920-3	CAP SQUARE NECK BOLT M6X30	2	PC.
	INC.		341003-8	PRESSURE PLATE	1	PC.
	INC.		411174-6	SHARPENING HOLDER	1	PC.
A02			123062-2	BLADE GAUGE ASS'Y	1	PC.
	INC.		911228-4	PAN HEAD SCREW M5X18	2	PC.
	INC.		411086-3	GAUGE PLATE	1	PC.
			123010-1	BLADE GAUGE ASS'Y	1	PC.
	INC.		911228-4	PAN HEAD SCREW M5X18	2	PC.
	INC.		411086-3	GAUGE PLATE	1	PC.
A03			782209-3	SOCKET WRENCH 9	1	PC.
A04			824944-8	PLASTIC CARRYING CASE	1	PC.
	INC.		417059-4	LATCH	2	PC.
	INC.		418889-6	HANDLE	1	PC.
A05			D-16966	3-1/4" MINI PLANER BLADE 35DEGREE, 2PC/SET	1	SET
			793322-2	3-1/4" MINI PLANER BLADE 50DEGREE, 2PC/SET	1	SET
			A-82921	3-1/4" MINI PLANER BLADE 65DEGREE, 2PC/SET	1	SET
A06			191455-1	GUIDE RULE SET (BEVEL GUIDE)	1	SET
	INC.		164371-0	GUIDE RULE (RIP FENCE)	1	PC.
	INC.		251812-6	SCREW	1	PC.
	Opt.		123060-6	GUIDE RULE ASS'Y	1	PC.
	INC.		923211-9	CAP SQUARE NECK BOLT M5X12	2	PC.
	INC.		911221-8	PAN HEAD SCREW M5X16	2	PC.
	INC.		934201-7	WING NUT M5	2	PC.
	INC.		256612-9	PIN 5	1	PC.
A07			132309-3	DRUM ASS'Y - N/A	1	PC.
	INC.			Item No. 39,52,54,55		
A08			D-17223	3-1/4" CARBIDE TIPPED PLANER BLADE, 2PC/SET	1	SET
			D-17217	3-1/4" HIGH SPEED STEEL PLANER BLADE, 2PC/SET	1	SET
A09			D-17239	SET PLATE AND 3-1/4" MINI PLANER BLADE SET	1	SET
A10			794061-7	DRESSING STONE 150-1200 (7LANGUAGES)	1	PC.
A11			122194-2	NOZZLE ASS'Y		PC.
	INC.		256612-9	PIN 5	1	PC.
	INC.		152122-3	NOZZLE FOR DUST BAG	1	PC.
	INC.		213601-7	O RING 50	1	PC.
	INC.		411311-2	ELBOW	1	PC.
A12			122230-4	DUST BAG ASS'Y	1	PC.
	INC.		152122-3	NOZZLE FOR DUST BAG	1	PC.
	INC.		213601-7	O RING 50	1	PC.
A13			STEX122275	JOINT 55 ASS'Y	1	PC.
A14			191725-8	EXTENSION GUIDE SET	1	SET
	INC.		911201-4	PAN HEAD SCREW M5X8	2	PC.
	INC.		252045-6	SQUARE NUT M5	2	PC.
A15			181572-5	NOZZLE SET (USE WITH A13, CONNECT TO HOSE)	1	PC.

SERVICE CHANGES

1. Changes on Main Frame, Handle Cover, etc.

Item No.	Description	Type 1 (MJ)	Type 2 (MJ/MCA)	Type 3 (MCA)	Type 4 (MCA)
1	Screw		911128-8	265874-8	265941-9
6	Main Frame		159351-9		159858-5
12	Screw	911138-5	911133-5		265941-9
14	Switch	651234-4		651232-8	
15	Handle Cover	410187-4	411172-0		415676-4
16	Screw		911148-2		265875-6
24	Screw		911128-8		265871-4
26	P.H.Screw M4x10		911111-5		-----
27	Bearing Cover		285012-6		-----
35	Screw		911226-8		265878-0
37	Rubber Pin		263002-9		-----
40	Rubber Pin	263013-4	263014-2		-----
41	Screw		251334-6 or 911581-8		265877-2
43	Screw		911136-9		265875-6

Above parts are completely interchangeable as a set.

2. Changes on Flat Washer 10 (T/I# 65936)

Item No.	Description	Type 1	Type 2
5	Flat Washer 10	253796-4	941251-5

Note: When replacing the current Flat Washer 10 (Pt. No. 253796-4) by the new one (Pt. No. 941251-5), always adjust depth of cut so that Front Base will be level with Rear Base. Then stick Scale Label on Knob so that graduation of "0" on the Scale Label will be aligned with arrow on the machine as shown below.

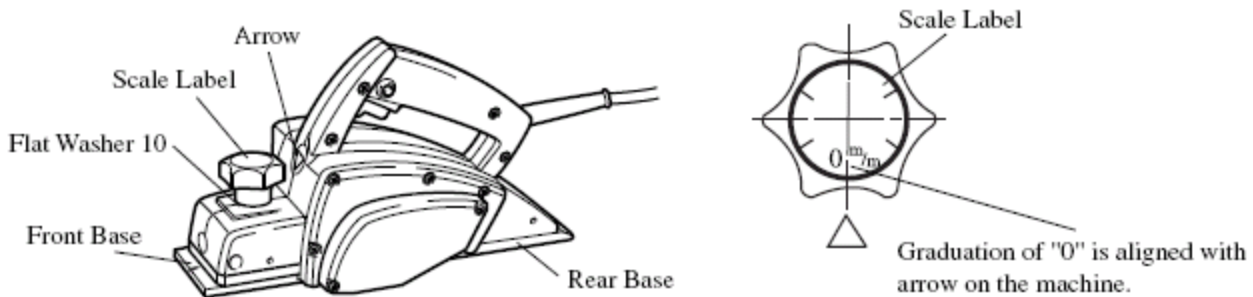

3. Changes on V-Pulley (T/I# 58869)

Item No.	Description	Type 1	Type 2
44	V-Pulley 4-20L	222008-6	222125-2
49	V-Pulley 4-37	222009-4	222126-0

Above parts are completely interchangeable as a set.



4. Changes on Adjusting Plate (T/I# 86322)

Item No.	Description	Type 1	Type 2
52	Adjusting Plate	342430-2	345644-2
53	Screw	251246-3	265132-2

Above parts are completely interchangeable as a set.

